

## Kit paracolpi in tubi Tube bull bar kit



### Simbologia

Per una lettura rapida e razionale sono stati impiegati simboli che evidenziano situazioni di massima attenzione, consigli pratici o semplici informazioni.

Prestare molta attenzione al significato dei simboli, in quanto la loro funzione è quella di non dovere ripetere concetti tecnici o avvertenze di sicurezza. Sono da considerare, quindi, dei veri e propri "promemoria".

Consultare questa pagina ogni volta che sorgeranno dubbi sul loro significato.



#### Attenzione

La non osservanza delle istruzioni riportate può creare una situazione di pericolo e causare gravi lesioni personali e anche la morte.



#### Importante

Indica la possibilità di arrecare danno al veicolo e/o ai suoi componenti se le istruzioni riportate non vengono eseguite.



#### Note

Fornisce utili informazioni sull'operazione in corso.

### Riferimenti

I particolari evidenziati in grigio e riferimento numerico (Es. ①) rappresentano l'accessorio da installare e gli eventuali componenti di montaggio forniti a kit.

I particolari con riferimento alfabetico (Es. A) rappresentano i componenti originali presenti sul motoveicolo.

Tutte le indicazioni destro o sinistro si riferiscono al senso di marcia del motociclo.

### Avvertenze generali



#### Attenzione

Le operazioni riportate nelle pagine seguenti devono essere eseguite da un tecnico specializzato o da un'officina autorizzata DUCATI.



#### Attenzione

Le operazioni riportate nelle pagine seguenti se non eseguite a regola d'arte possono pregiudicare la sicurezza del pilota.



#### Note

Documentazione necessaria per eseguire il montaggio del Kit è il MANUALE OFFICINA, relativo al modello di moto in vostro possesso.



#### Note

Nel caso fosse necessaria la sostituzione di un componente del kit consultare la tavola ricambi allegata.

### Symbols

To allow quick and easy consultation, this manual uses graphic symbols to highlight situations in which maximum care is required, as well as practical advice or information.

Pay attention to the meaning of the symbols since they serve to avoid repeating technical concepts or safety warnings throughout the text. The symbols should therefore be seen as real reminders. Please refer to this page whenever in doubt as to their meaning.



#### Warning

Failure to follow these instructions might give rise to a dangerous situation and provoke severe personal injuries or even death.



#### Caution

Failure to follow these instructions might cause damages to the vehicle and/or its components.



#### Notes

Useful information on the procedure being described.

### References

Parts highlighted in grey and with a numeric reference (Example ①) are the accessory to be installed and any assembly components supplied with the kit.

Parts with an alphabetic reference (Example A) are the original components fitted on the vehicle.

Any right- or left-hand indication refers to the vehicle direction of travel.

### General notes



#### Warning

Carefully perform the operations on the following pages since they might negatively affect rider safety.



#### Warning

Carefully perform the operations on the following pages since they might negatively affect rider safety.



#### Notes

The following documents are necessary for assembling the Kit: WORKSHOP MANUAL of your bike model.



#### Notes

Should it be necessary to change any kit parts, please refer to the attached spare part table.

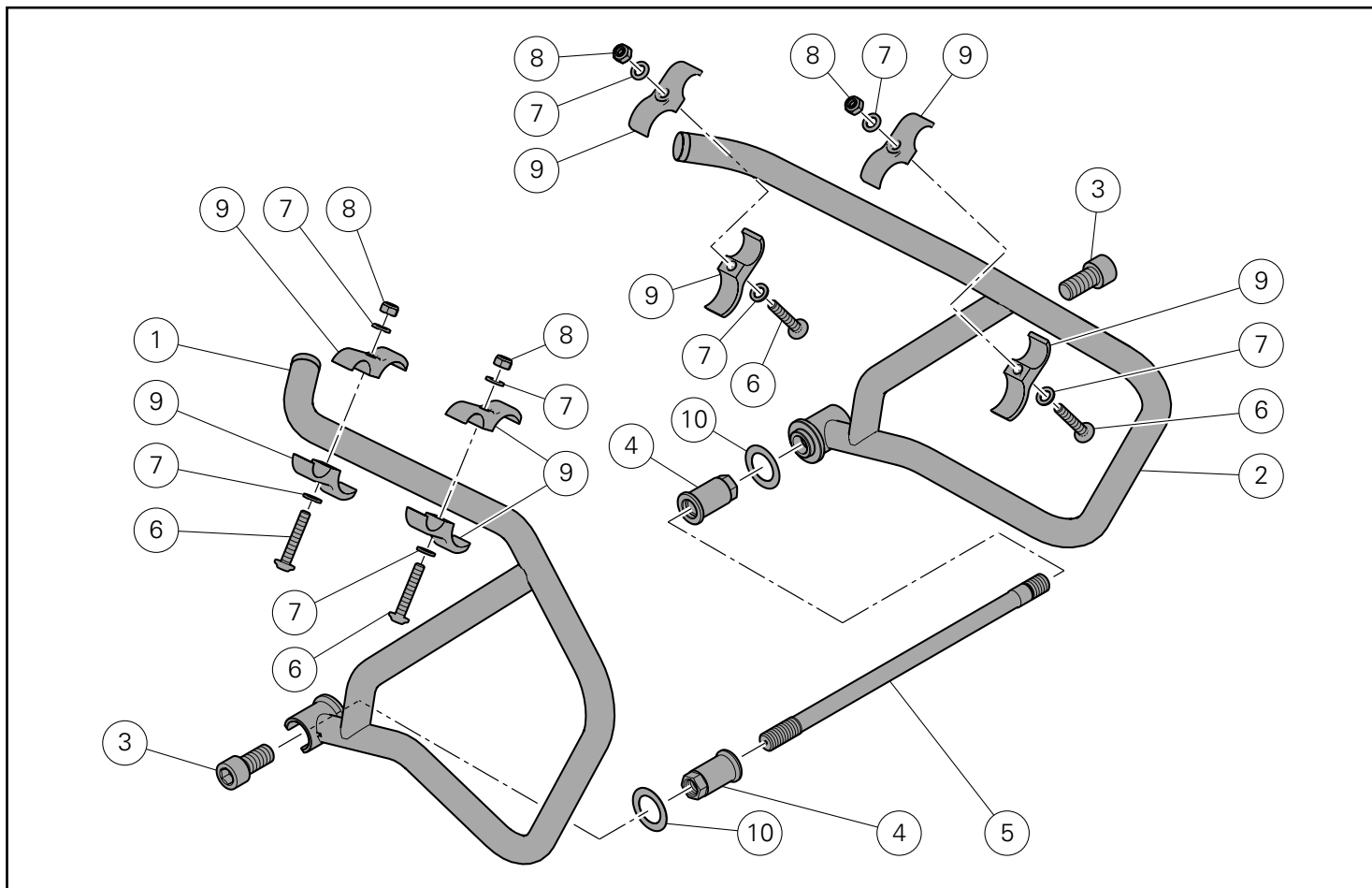

Pos.	Denominazione	Description
1	Paramotore destro	RH engine protection
2	Paramotore sinistro	LH engine protection
3	Vite TCEI	TCEI screw
4	Dado speciale	Special nut
5	Vite speciale	Special screw
6	Vite	Screw
7	Rosetta	Washer
8	Dado autobloccante	Self-locking nut
9	Semimorsetto	Half clamp
10	Distanziale	Spacer

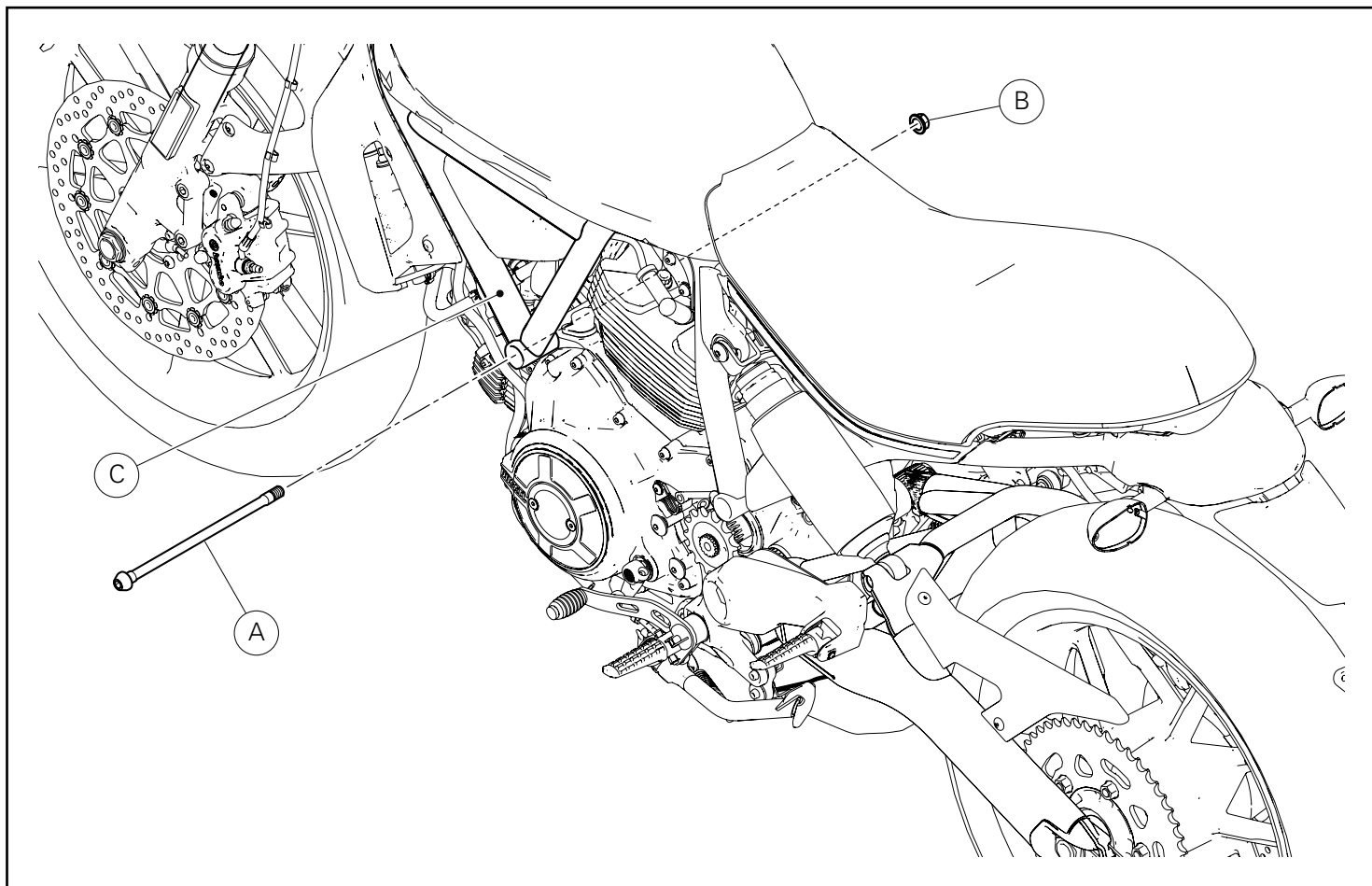

### Smontaggio componenti originali

### Removing the original components

#### Smontaggio vite speciale telaio

#### Removing the frame special screw



#### Importante

Durante la procedura di smontaggio della vite speciale telaio supportare adeguatamente il blocco motore



#### Caution

During the frame special screw removal procedure, support the engine unit adequately

Svitare la vite speciale (A) dal telaio (C), mantenendo dal lato opposto, il dado (B).

Rimuovere il dado (B).

Loosen the special screw (A) from the frame (C), while holding nut (B) on the opposite side.

Remove nut (B).

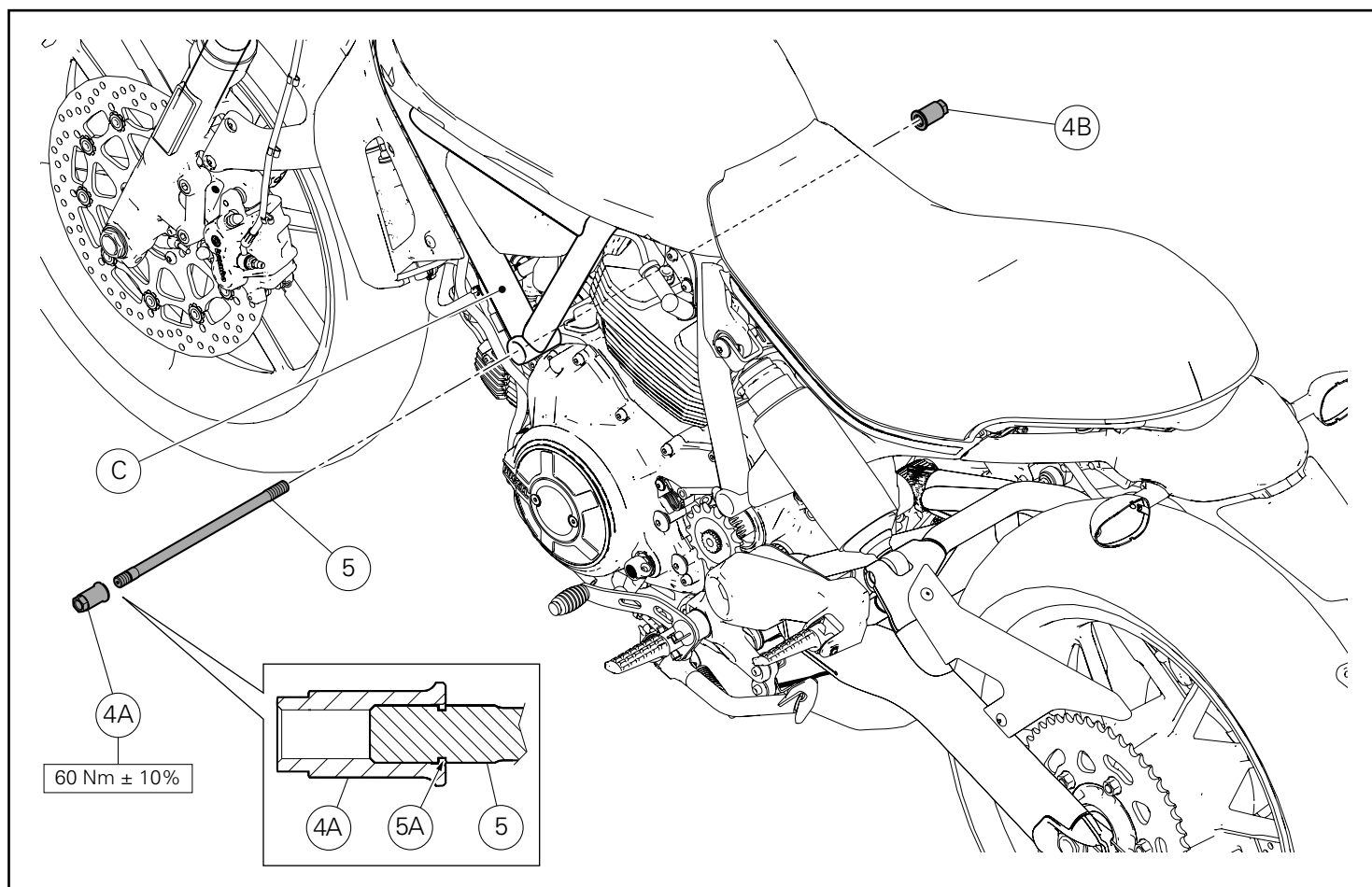

## Montaggio componenti kit

### ● Importante

Verificare, prima del montaggio, che tutti i componenti risultino puliti e in perfetto stato.  
Adottare tutte le precauzioni necessarie per evitare di danneggiare qualsiasi parte nella quale ci si trova ad operare.

### Montaggio vite speciale

Applicare LOCTITE 601 sulla filettatura dei n.2 dadi speciali (4A) e (4B).

Montare il dado speciale (4A) sulla vite speciale (5), avvitandolo sino alla scanalatura (5A) presente sulla vite stessa, come indicato nel riquadro.

Applicare GRASSO bianco su tutto lo stelo della vite speciale (5) facendo attenzione a non applicarlo sul filetto.

Introdurre la vite speciale (5) sul telaio (C), portando a battuta il dado speciale (4A).

Impuntare dal lato opposto il secondo dado speciale (4B).

Serrare il primo dado (4A) alla coppia indicata, mantenendo dal lato opposto il secondo dado (4B).

## Kit installation

### ● Caution

Check that all components are clean and in perfect condition before installation.  
Adopt any precaution necessary to avoid damages to any part of the motorcycle you are working on.

### Special screw assembly

Apply LOCTITE 601 on the threading of the 2 special nuts (4A) and (4B).

Fit the special nut (4A) to the special screw (5), and tighten it up to the groove (5A) present on the screw, as indicated in the box.

Apply white GREASE over the whole pin of special screw (5) paying attention not to smear the thread.

Fit the special screw (5) to the frame (C), bringing the special nut (4A) fully home.

On the opposite side, start the special nut (4B).

Tighten the first nut (4A) to the specified torque while holding the second nut (4B) from the opposite side.

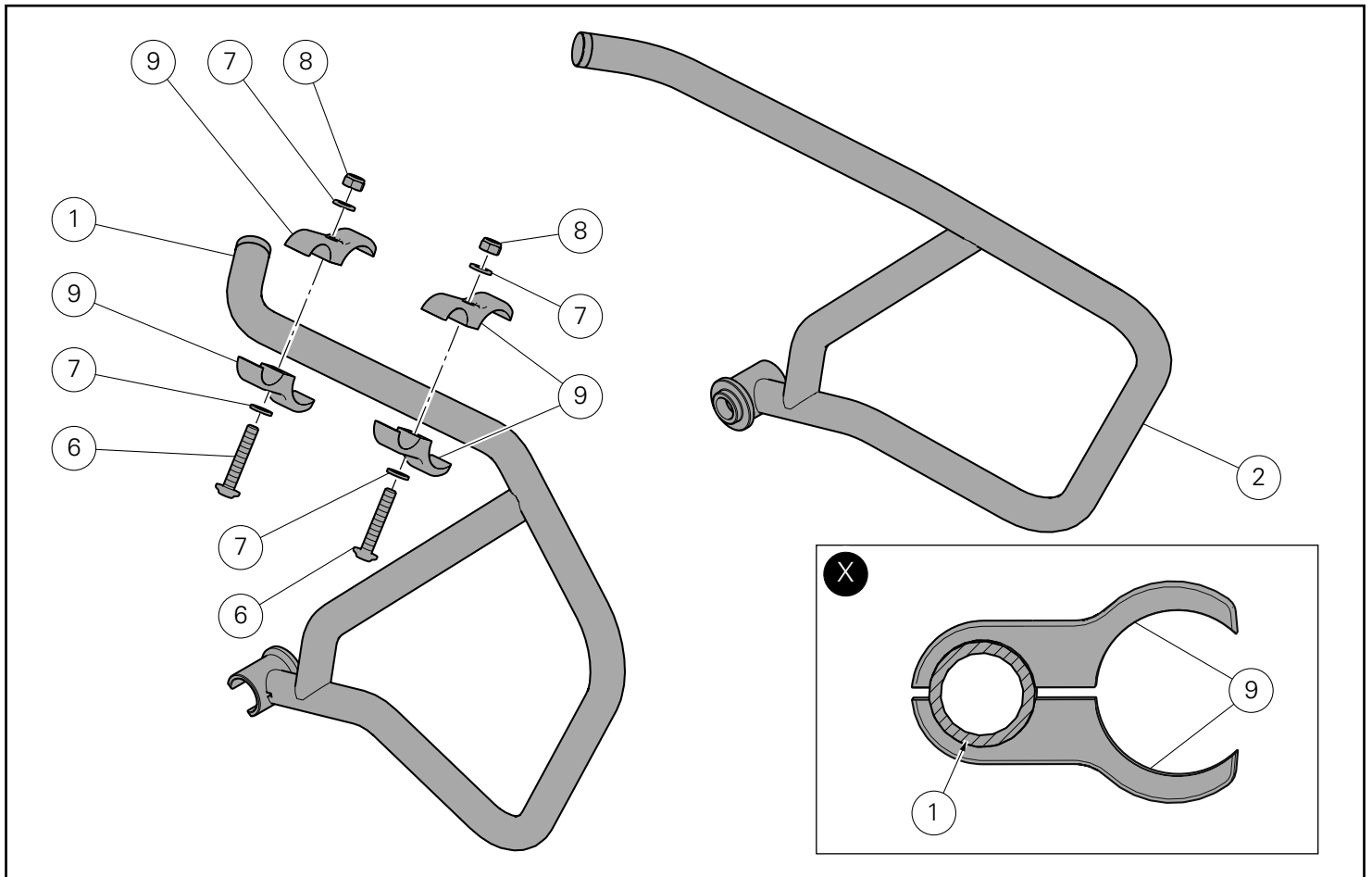

**Premontaggio semimorsetti su paramotore**

Inserire la rondella (7) sulla vite (6).  
 Posizionare i n.2 semimorsetti (9) sul paramotore destro (1) come mostrato in figura (X) e impuntare la vite (6) dal basso.  
 Dal lato superiore, sulla sporgenza della vite (6), inserire la rondella (7) e avvitare leggermente il dado autobloccante (8).  
 Ripetere la stessa operazione per il montaggio del secondo morsetto sul paramotore destro (1) e per i n.4 semimorsetti sul paramotore sinistro (2).

**Pre-assembly of half clamps on engine protection**

Fit washer (7) on screw (6).  
 Position no. 2 half clamps (9) on the RH engine protection (1) as shown in the figure (X) and start screw (6) from the bottom.  
 From the upper side, on the screw (6) projection, fit washer (7) and slightly screw the self-locking nut (8).  
 Repeat the same operation to fit the second clamp on the RH engine protection (1) and for the 4 half clamps on the LH engine protection (2).

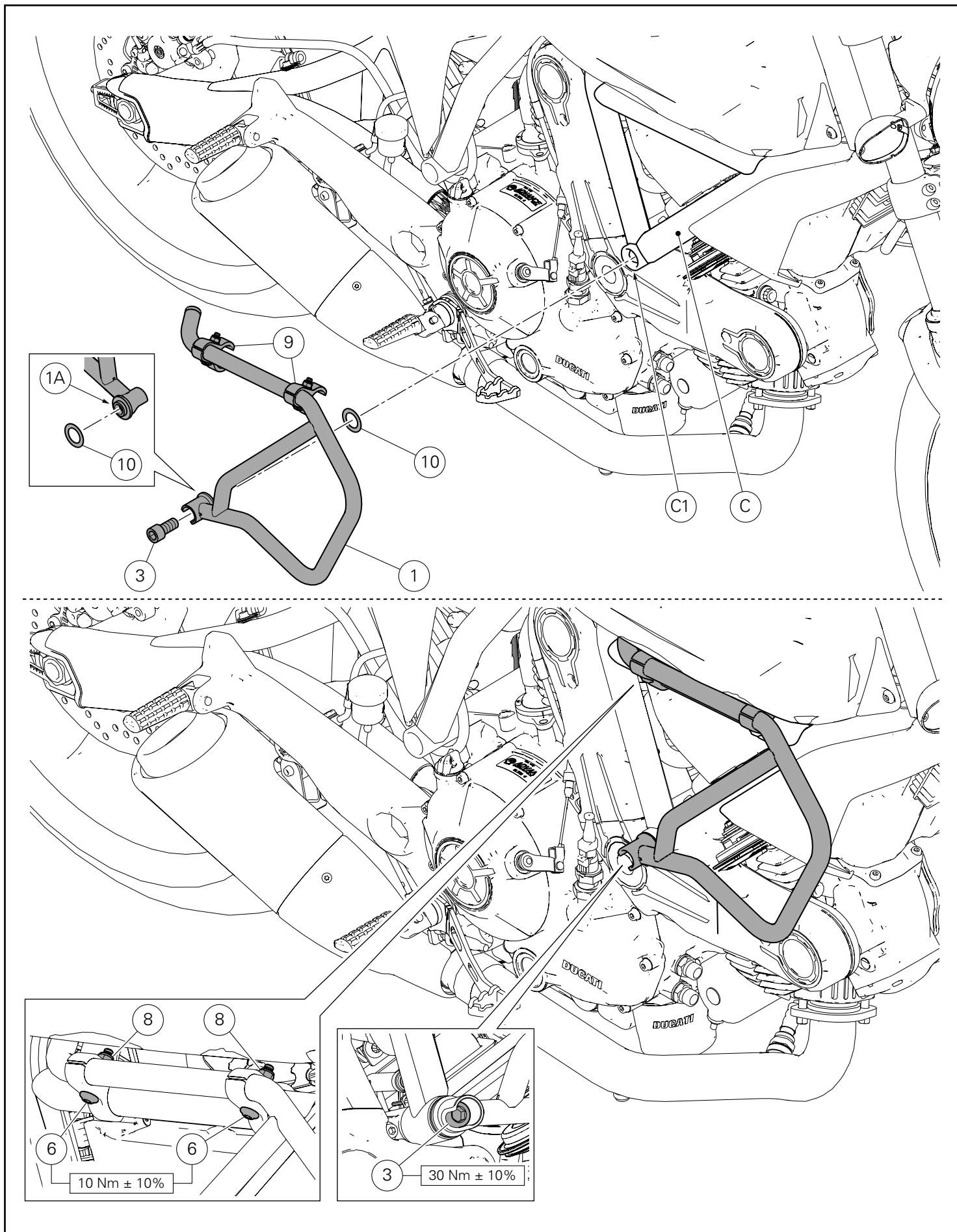

### Montaggio paramotore

Operando dal lato destro del motoveicolo, agganciare i semimorsetti (9) sul telaio (C).

Inserire l'appendice (1A) nella sede (C1), interponendo il distanziale (10).

Impuntare la vite (3) sul paramotore destro (1).

Serrare le n.2 viti (6) alla coppia indicata, mantenendo dal lato opposto i n.2 dadi (8).

Serrare la vite 3 alla coppia indicata.

Ripetere la stessa operazione per il montaggio del paramotore sinistro.

### Fitting the engine protection

Working on the motorcycle RH side, fit the half clamps (9) onto frame (C).

Insert protrusion (1A) into seat (C1) with spacer (10) in between. Start screw (3) on RH engine protection (1).

Tighten no. 2 screws (6) to the specified torque while holding no. 2 nuts (8) from the opposite side.

Tighten screw 3 to the specified torque.

Repeat the same procedure to assemble LH engine protection.





## Kit pare-chocs en tubes Kit Schlagschutz in Rohrstruktur



### Symboles

Pour faciliter la consultation de ce manuel, des symboles signalent des situations exigeant le maximum d'attention, des conseils pratiques ou de simples informations. Lire attentivement la signification de ces symboles car ils renvoient à des concepts techniques ou des consignes de sécurité de la plus grande importance. Ils doivent être considérés comme de véritables « aide-mémoire ». Toujours consulter cette page en cas de doute concernant leur signification.



#### Attention

La non-observance des instructions reportées ci-dessous peut créer une situation dangereuse et provoquer de graves lésions personnelles voire la mort.



#### Important

Indique la possibilité d'endommager le véhicule et/ou ses composants si les instructions reportées ci-dessous ne sont pas suivies.



#### Remarques

Fournit des informations utiles sur l'opération en cours.

### Références

Les pièces surlignées en gris et la référence numérique (Ex. ①) représentent l'accessoire à installer et les composants de montage éventuels fournis en kit.

Les pièces avec référence alphabétique (Ex. Ⓐ) représentent les composants d'origine présents sur le motorcycle.

Toutes les indications droite ou gauche se réfèrent au sens de marche la moto.

### Avertissements généraux



#### Attention

Les opérations indiquées dans les pages suivantes, au cas où elles ne seraient pas effectuées selon les règles de l'art pourraient compromettre la sécurité du pilote.



#### Attention

Les opérations indiquées dans les pages suivantes, au cas où elles ne seraient pas effectuées selon les règles de l'art pourraient compromettre la sécurité du pilote.



#### Remarques

La documentation nécessaire pour effectuer la pose du Kit est le : MANUEL D'ATELIER, relatif au modèle de moto en votre possession.



#### Remarques

Au cas où il serait nécessaire d'effectuer le remplacement d'un composant du kit, il faudra consulter la planche relative aux pièces détachées ci-jointe.

### Symbole

Zum schnellen und übersichtlichen Lesen werden Symbole verwendet, die außerordentlich wichtige Situationen, praktische Ratschläge oder auch nur einfache Informationen hervorheben. Der Bedeutung dieser Symbole ist besondere Aufmerksamkeit zu schenken, da sich hierdurch das ständige Wiederholen von technischen Konzepten oder Sicherheitshinweisen erübrigt. Sie stellen daher regelrechte „Merker“ dar. Diese Seite ist immer dann zur Hand zu nehmen, wenn Zweifel über die Bedeutung eines Symbols bestehen sollten.



#### Achtung

Eine Nichtbeachtung der hier wiedergegebenen Anweisungen kann Gefahrensituationen schaffen und zu schweren Verletzungen und auch zum Tod führen.



#### Wichtig

Weist darauf hin, dass bei Nichteinhaltung der hier wiedergegebenen Anweisungen die Möglichkeit für Schäden am Fahrzeug und/oder seiner Komponenten besteht.



#### Hinweis

Übermittelt nützliche Informationen zum betreffenden Arbeitseingriff.

### Bezugsangaben

Die grau gekennzeichneten Bestandteile mit numerischem Bezug (Bsp. ①) geben das zu installierende Bestandteil und die eventuellen, im Kit enthaltenen Montagekomponenten wieder.

Die Bestandteile mit alphabetischem Bezug (Bsp. Ⓐ) geben die Original-Bestandteile wieder, die am Motorrad verbaut wurden.

Alle Angaben wie „rechts“ oder „links“ beziehen sich auf die Fahrtrichtung des Motorrads.

### Allgemeine Warnhinweise



#### Achtung

Werden die auf den folgenden Seiten beschriebenen Arbeitsmaßnahmen nicht fachgerecht ausgeführt, kann sich dies auf die Sicherheit des Fahrers auswirken.



#### Achtung

Werden die auf den folgenden Seiten beschriebenen Arbeitsmaßnahmen nicht fachgerecht ausgeführt, kann sich dies auf die Sicherheit des Fahrers auswirken.



#### Hinweis

Für die Montage des Kits sind folgende Unterlagen erforderlich: WERKSTATTANDBUCH, des sich in Ihrem Besitz befindlichen Motorrads.



#### Hinweis

Sollte sich der Austausch eines Bestandteils des Kits als erforderlich erweisen, ist dazu Bezug auf die beiliegende Ersatzteilliste zu nehmen.

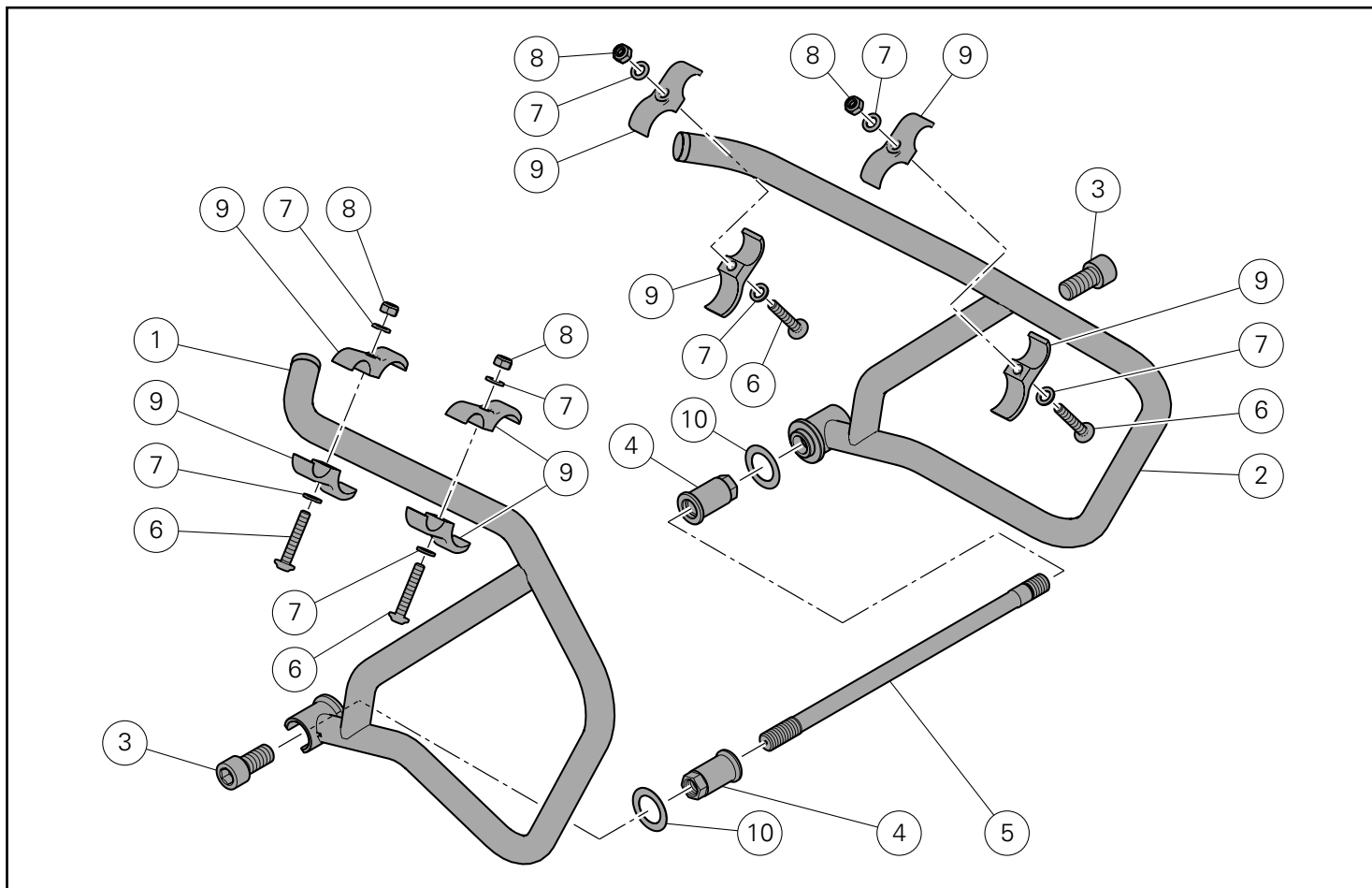

Pos.	Designation	Bezeichnung
1	Pare-moteur droit	Motorschutz, rechts
2	Pare-moteur gauche	Motorschutz, links
3	Vis TCHC	Innensechskantschraube
4	Écrou spécial	Spezialmutter
5	Vis spéciale	Spezialschraube
6	Vis	Schraube
7	Rondelle	Unterlegscheibe
8	Écrou autobloquant	Selbstsichernde Mutter
9	Demi-collier	Klemmfausthälfte
10	Entretoise	Distanzstück

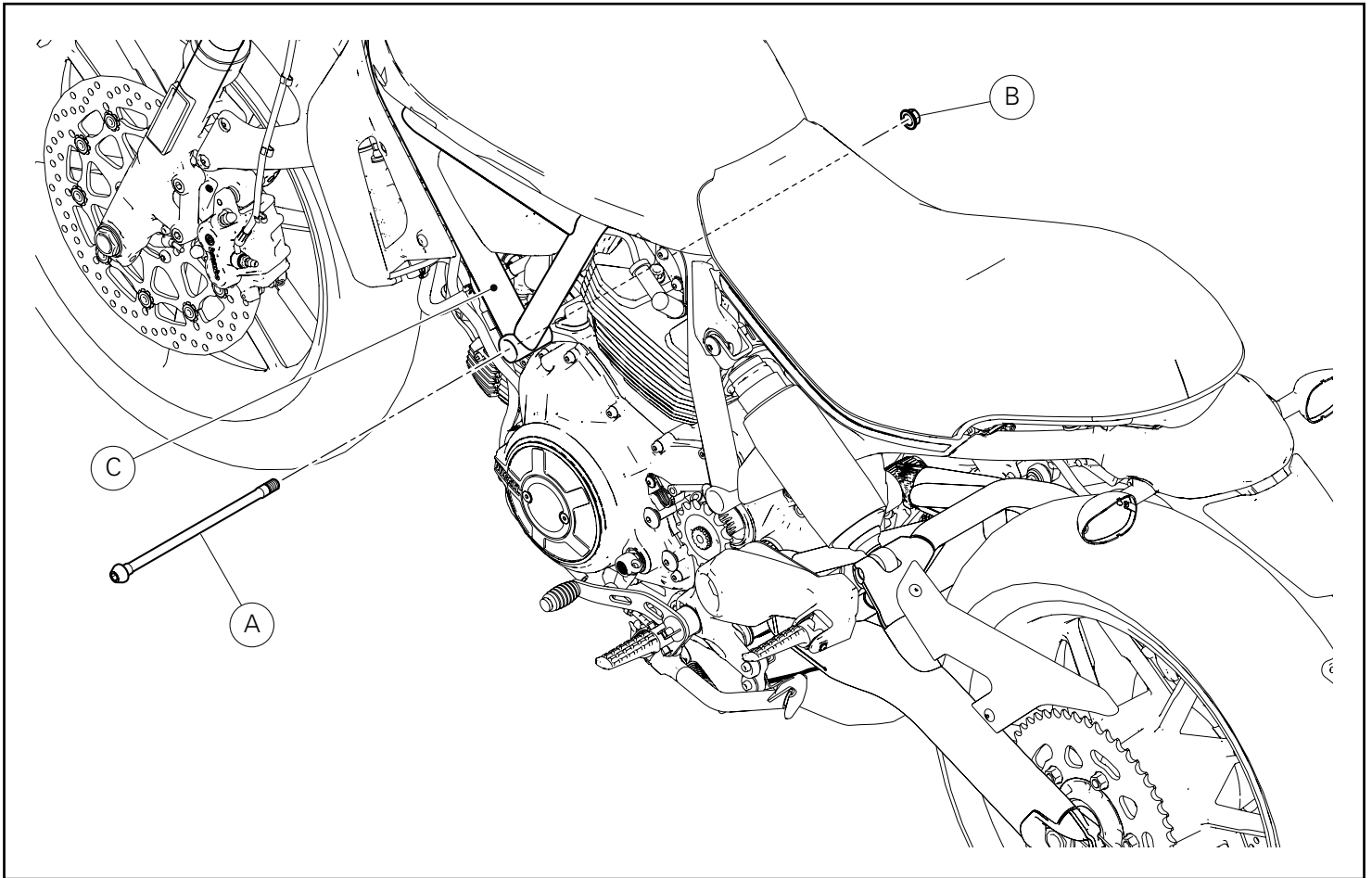

## Dépose composants d'origine

### Dépose de la vis spéciale cadre



#### Important

Pendant la procédure de dépose de la vis spéciale cadre soutenir adéquatement le carter moteur

Desserrer la vis spéciale (A) du cadre (C) en maintenant l'écrou (B) du côté opposé.  
Retirer l'écrou (B).

## Ausbau der Original-Bestandteile

### Lösen der Spezialschraube für Rahmen



#### Wichtig

Beim Ausbau der Spezialschraube des Rahmens muss der Motorblock in angemessener Weise abgestützt werden

Die Spezialschraube (A) vom Rahmen (C) lösen, während man von der Gegenseite die Mutter (B) kontert.  
Die Mutter (B) entfernen.

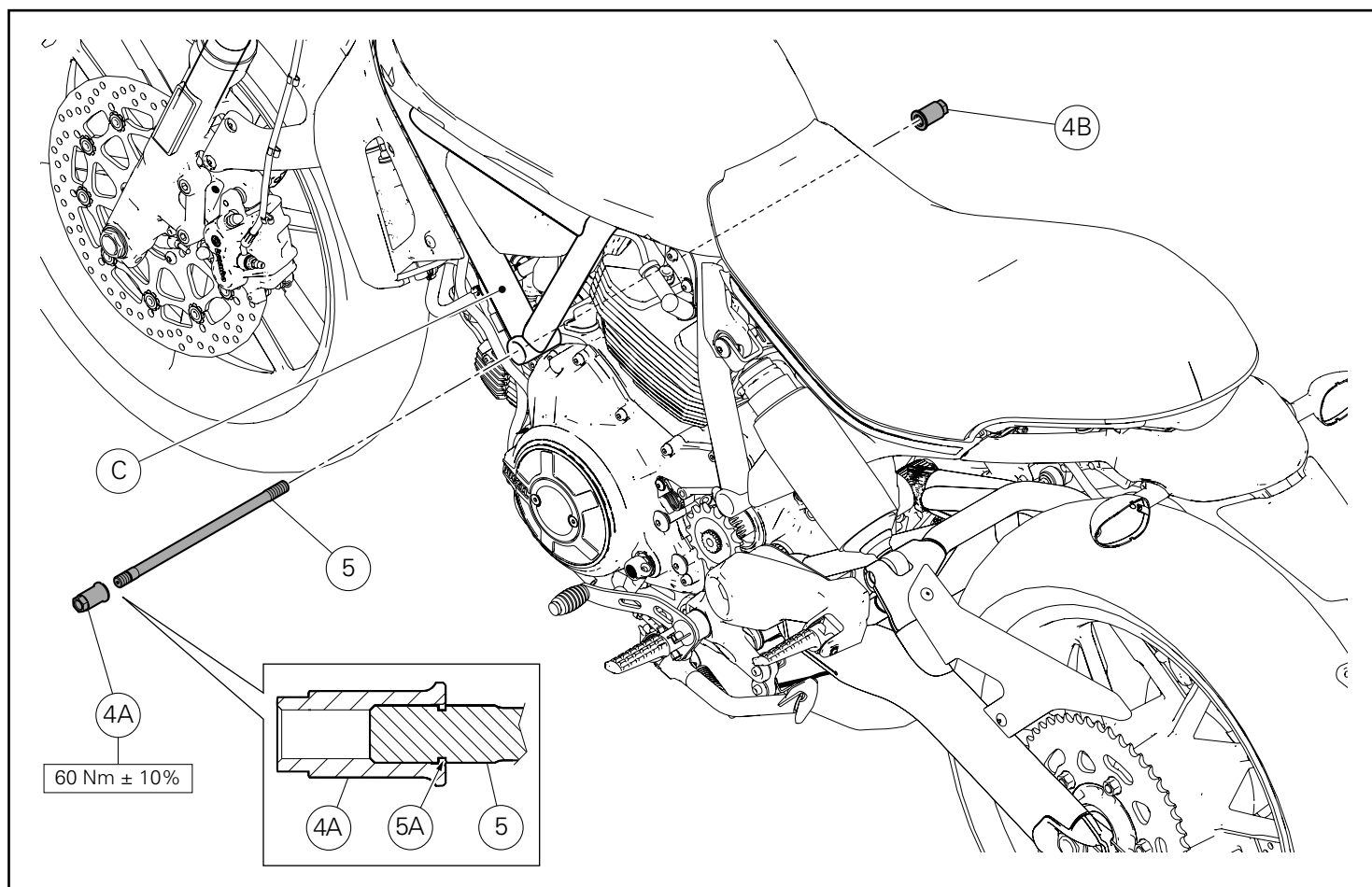

## Pose composants kit



### Important

Vérifier, avant la pose, que tous les composants sont propres et en parfait état.

Adopter toutes les précautions nécessaires pour éviter d'endommager la surface externe des composants où on opère.

### Pose de la vis spéciale

Appliquer du LOCTITE 601 sur le filetage des 2 écrous spéciaux (4A) et (4B).

Poser l'écrou spécial (4A) sur la vis spéciale (5) en le vissant jusqu'au niveau de la rainure (5A) présente sur la vis (voir encadré).

Enduire de GRAISSE blanche toute la tige de la vis spéciale (5) en prenant garde de ne pas appliquer la graisse sur le filet.

Insérer la vis spéciale (5) sur le cadre (C) en faisant buter l'écrou spécial (4A).

Présenter le second écrou spécial (4B) du côté opposé.

Serrer le premier écrou (4A) au couple prescrit en maintenant le second écrou (4B) du côté opposé.

## Montage der Komponenten des Kits



### Wichtig

Vor der Montage überprüfen, dass sich alle Komponenten im sauberen und perfekten Zustand befinden.

Alle erforderlichen Vorsichtsmaßnahmen treffen, um eine Beschädigung der Oberflächen der Komponenten, die vom Eingriff betroffen sind, zu vermeiden.

### Montage der Spezialschraube

LOCTITE 601 auf das Gewinde der 2 Spezialmutter (4A) und (4B) auftragen.

Die Spezialmutter (4A) auf der Spezialschraube (5) bis zum Erreichen der an der Schraube vorhandenen Nut (5A) gemäß der Angaben im Detailausschnitt aufschrauben.

Das weiße FETT auf den Schaft der Spezialschraube (5) auftragen und dabei darauf achten, dass es nicht auf das Gewinde gelangt.

Die Spezialschraube (5) am Rahmen (C) einsetzen und die Spezialmutter (4A) auf Anschlag bringen.

Die zweite Spezialmutter (4B) von der entgegengesetzten Seite her ansetzen.

Die erste Mutter (4A) mit dem angegebenen Anzugsmoment anziehen, dabei an der gegenüberliegenden Seite die zweite Mutter (4B) kontern.

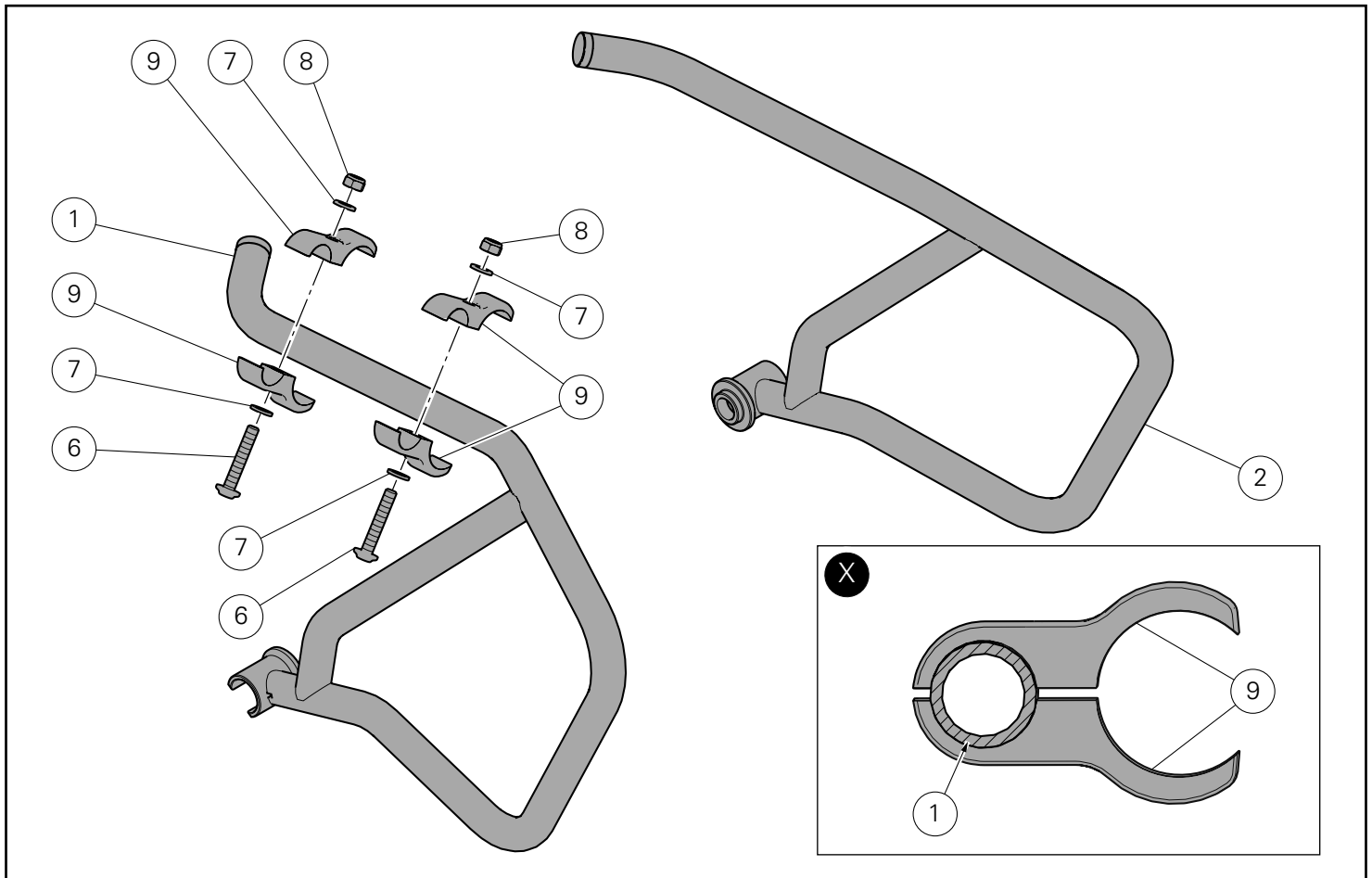

#### Pré-montage demi-colliers sur pare-moteur

Insérer la rondelle (7) sur la vis (6).  
Positionner les 2 demi-colliers (9) sur le pare-moteur droit (1) comme la figure le montre (X) et présenter la vis (6) du bas.  
Du côté supérieur, insérer la rondelle (7) sur la saillie de la vis (6) et visser légèrement l'écrou autobloquant (8).  
Répéter la même opération pour la pose du deuxième collier sur le pare-moteur droit (1) et pour les 4 demi-colliers sur le pare-moteur gauche (2).

#### Vormontage der Klemmfausthälften am Motorschutz

Die Unterlegscheibe (7) auf die Schraube (6) fügen.  
Die 2 Klemmfausthälften (9), wie auf der Abbildung (X) dargestellt, am rechten Motorschutz (1) anordnen und die Schraube (6) von unten her ansetzen.  
Die Unterlegscheibe (7) von oben auf den vorstehenden Teil der Schraube (6) fügen, dann die selbstsichernde Mutter (8) etwas anziehen.  
In der gleichen Weise bei der Montage der zweiten Klemmfaust am rechten Motorschutz (1) und den 4 Klemmfausthälften am linken Motorschutz (2) verfahren.

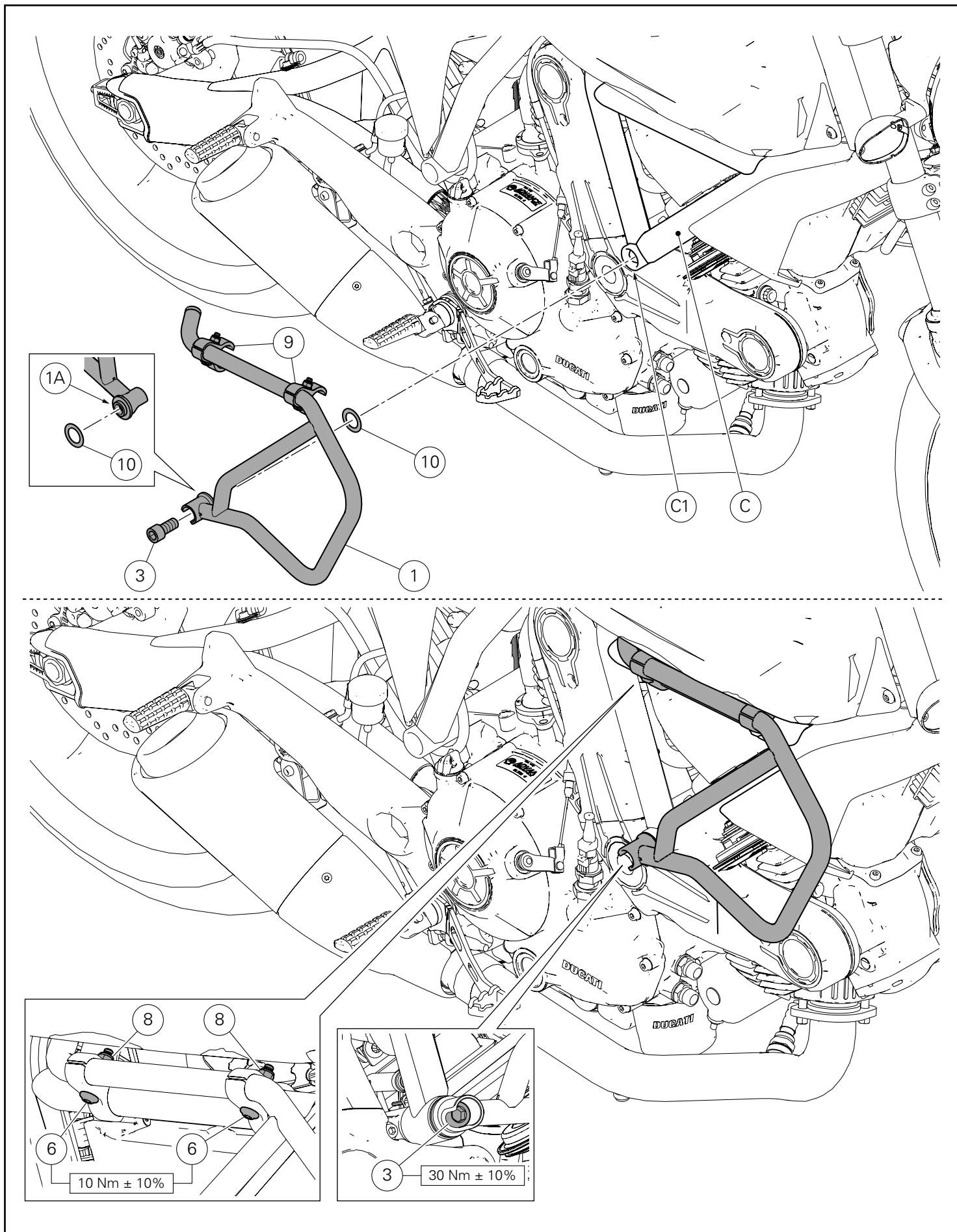

### Pose du pare-moteur

En agissant du côté droit du motorcycle, accrocher les demi-colliers (9) sur le cadre (C).

Insérer l'appendice (1A) dans le logement (C1), en interposant l'entretoise (10).

Présenter la vis (3) sur le pare-moteur droit (1).

Serrer les 2 vis (6) au couple prescrit en maintenant les 2 écrous (8) du côté opposé.

Serrer la vis (3) au couple prescrit.

Répéter la même opération pour installer le pare-moteur gauche.

### Montage des Motorschutzes

Die Klemmfausthälften (9) an der rechten Seite des Rahmens (C) einhaken.

Den Anlussteil (1A) nach Anfügen des Distanzstücks (10) in den Sitz (C1) einfügen.

Die Schraube (3) am Motorschutz (1) ansetzen.

Die 2 Schrauben (6) mit dem angegebenen Anzugsmoment anziehen und dabei, an der gegenüberliegenden Seite, die 2 Muttern (8) kontern.

Die Schraube (3) mit dem angegebenen Anzugsmoment anziehen.

Das selbe Verfahren für die Montage des linken Motorschutzes wiederholen.





## Conjunto para-choques em tubos Tube bull bar kit



### Símbolos

Para uma leitura rápida e racional, foram utilizados símbolos que evidenciam situações de máxima atenção, conselhos práticos ou simples informações. Preste muita atenção ao significado dos símbolos, pois a sua função é a de evitar a repetição de conceitos técnicos ou de avisos de segurança. Portanto, os símbolos devem ser considerados como verdadeiros "lembretes". Consulte esta página sempre que tiver dúvidas acerca do seu significado.



#### Atenção

O não cumprimento das instruções mostradas pode criar uma situação de perigo e causar graves lesões pessoais e até mesmo a morte.



#### Importante

Indica a possibilidade de causar danos ao veículo e/ou aos seus componentes se as instruções mostradas não forem executadas.



#### Notas

Fornecer informações úteis sobre a operação em andamento.

### Referências

Os detalhes evidenciados em cinza e com referência numérica (Ex. ①) representam o acessório a ser instalado e os eventuais componentes de montagem fornecidos como kit.

Os detalhes com referência alfabética (Ex. A) representam os componentes originais presentes na moto.

Todas as indicações direita ou esquerda, referem-se ao sentido de marcha da moto.

### Advertências gerais



#### Atenção

As operações mostradas nas páginas a seguir, se não forem executadas com boa técnica, podem prejudicar a segurança do condutor.



#### Atenção

As operações mostradas nas páginas a seguir, se não forem executadas com boa técnica, podem prejudicar a segurança do condutor.



#### Notas

Documentação necessária para executar a montagem do Conjunto: MANUAL DE OFICINA, relativo ao modelo de moto em sua posse.



#### Notas

Caso seja necessária a substituição de um componente do conjunto, consulte o quadro de peças de reposição em anexo.

### Symbols

To allow quick and easy consultation, this manual uses graphic symbols to highlight situations in which maximum care is required, as well as practical advice or information.

Pay attention to the meaning of the symbols since they serve to avoid repeating technical concepts or safety warnings throughout the text. The symbols should therefore be seen as real reminders. Please refer to this page whenever in doubt as to their meaning.



#### Warning

Failure to follow these instructions might give rise to a dangerous situation and provoke severe personal injuries or even death.



#### Caution

Failure to follow these instructions might cause damages to the vehicle and/or its components.



#### Notes

Useful information on the procedure being described.

### References

Parts highlighted in grey and with a numeric reference (Example ①) are the accessory to be installed and any assembly components supplied with the kit.

Parts with an alphabetic reference (Example A) are the original components fitted on the vehicle.

Any right- or left-hand indication refers to the vehicle direction of travel.

### General notes



#### Warning

Carefully perform the operations on the following pages since they might negatively affect rider safety.



#### Warning

Carefully perform the operations on the following pages since they might negatively affect rider safety.



#### Notes

The following documents are necessary for assembling the Kit: WORKSHOP MANUAL of your bike model.



#### Notes

Should it be necessary to change any kit parts, please refer to the attached spare part table.

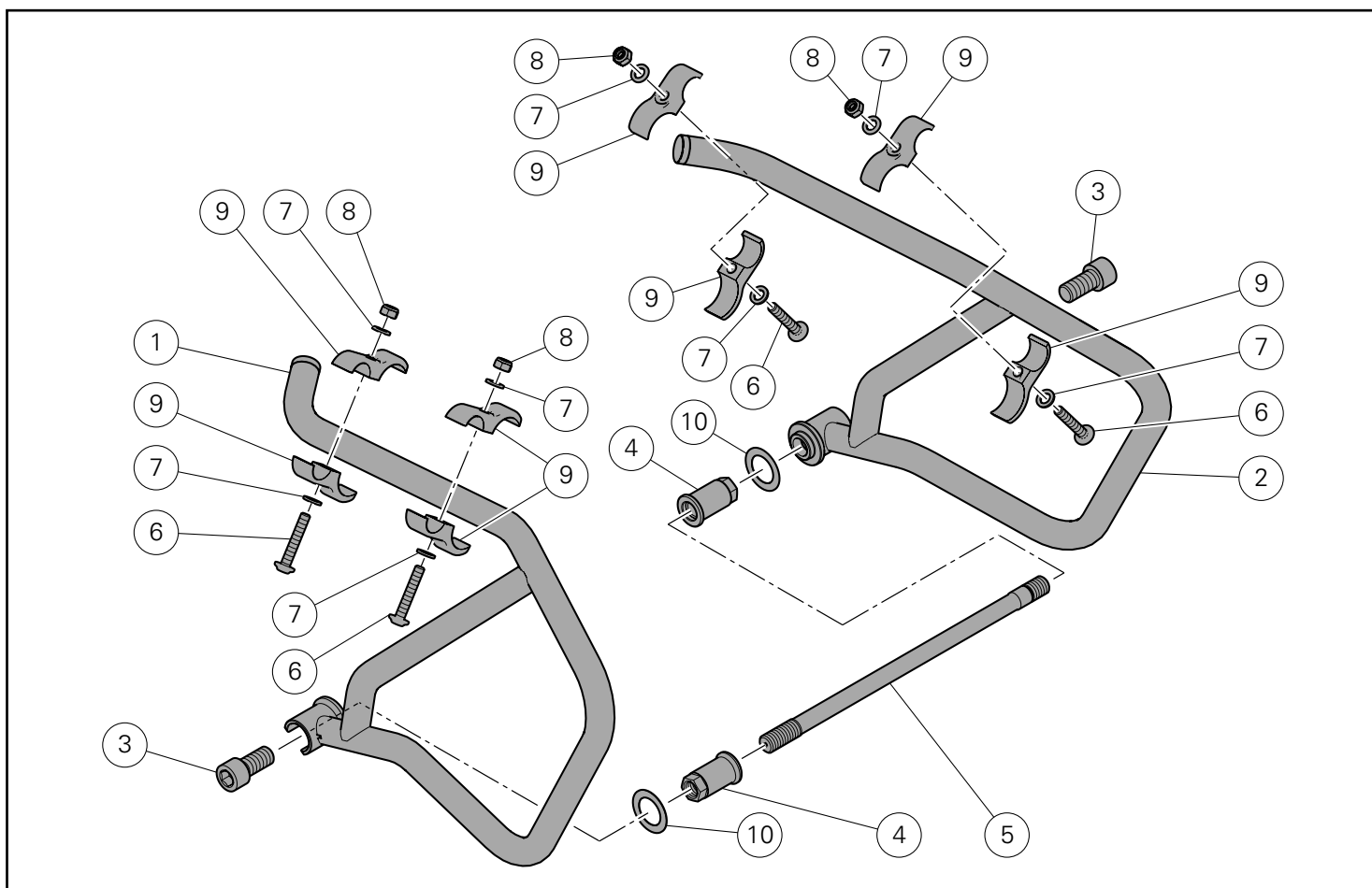

Pos.	Descrição	Description
1	Protetor direito do motor	RH engine protection
2	Protetor esquerdo do motor	LH engine protection
3	Parafuso de cabeça cilíndrica com sextavado interno	TCEI screw
4	Porca especial	Special nut
5	Parafuso especial	Special screw
6	Parafuso	Screw
7	Anilha	Washer
8	Porca autoblocante	Self-locking nut
9	Semiterminal	Half clamp
10	Espaçador	Spacer

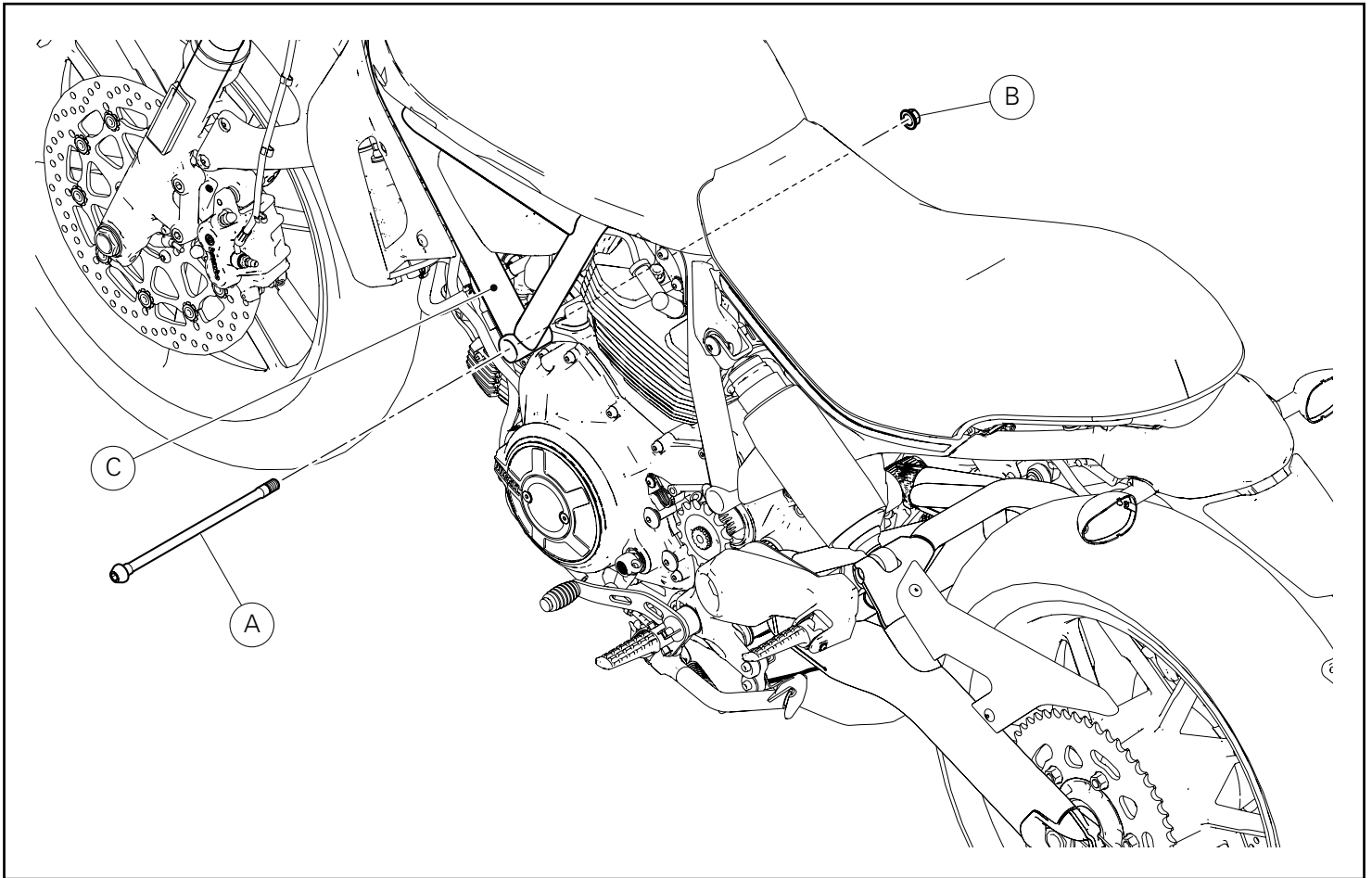

### Desmontagem dos componentes originais

### Removing the original components

#### Desmontagem do parafuso especial do chassi

#### Removing the frame special screw



#### Importante

Durante o procedimento de desmontagem do parafuso especial do chassi, suporte adequadamente o bloco do motor



#### Caution

During the frame special screw removal procedure, support the engine unit adequately

Desaparafusar o parafuso especial (A) do chassi (C) mantendo a porca (B) bem firme no lado oposto.  
Remover a porca (B).

Loosen the special screw (A) from the frame (C), while holding nut (B) on the opposite side.  
Remove nut (B).

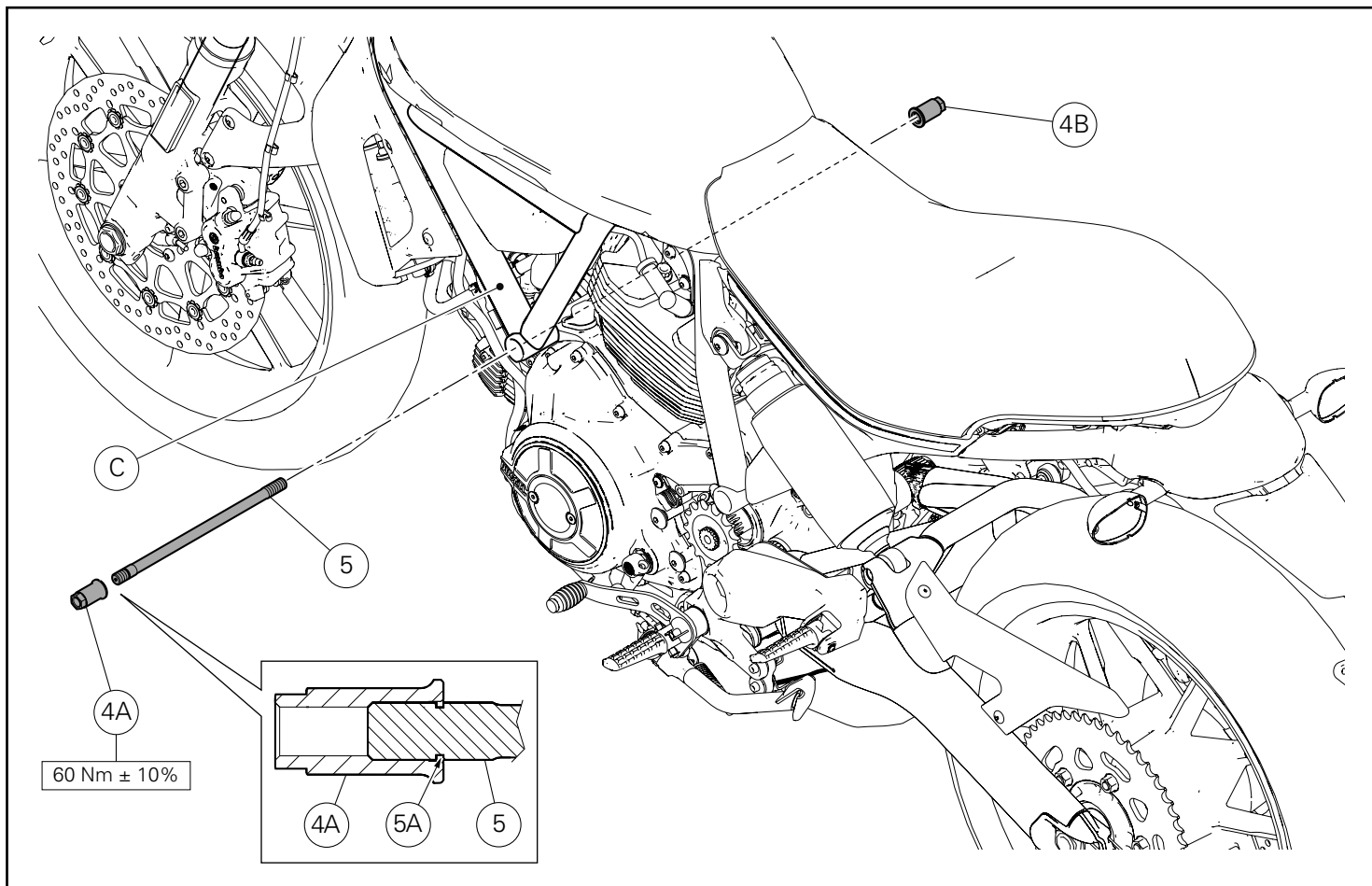

## Montagem dos componentes

### ● Importante

Verifique, antes da montagem, se todos os componentes estão limpos e em perfeito estado.  
Adote todas as precauções necessárias para evitar danificar qualquer peça com a qual deve trabalhar.

### Montagem do parafuso especial

Aplicar o produto LOCTITE 601 na rosca das 2 porcas especiais (4A) e (4B).

Montar a porca especial (4A) no parafuso especial (5), enroscando-a na ranhura (5A) presente na extremidade do próprio parafuso, conforme mostrado na figura.

Aplicar GRAXA branca ao longo de toda a haste do parafuso especial (5), prestando atenção para não atingir a rosca.

Introduzir o parafuso especial (5) no chassi (C), até atingir o fim-de-curso da porca especial (4A).

Encaixar no lado oposto a segunda porca especial (4B).

Apertar a primeira porca (4A) observando ao binário indicado, mantendo a segunda porca (4B) bem firme no lado oposto.

## Kit installation

### ● Caution

Check that all components are clean and in perfect condition before installation.  
Adopt any precaution necessary to avoid damages to any part of the motorcycle you are working on.

### Special screw assembly

Apply LOCTITE 601 on the threading of the 2 special nuts (4A) and (4B).

Fit the special nut (4A) to the special screw (5), and tighten it up to the groove (5A) present on the screw, as indicated in the box.

Apply white GREASE over the whole pin of special screw (5) paying attention not to smear the thread.

Fit the special screw (5) to the frame (C), bringing the special nut (4A) fully home.

On the opposite side, start the special nut (4B).

Tighten the first nut (4A) to the specified torque while holding the second nut (4B) from the opposite side.

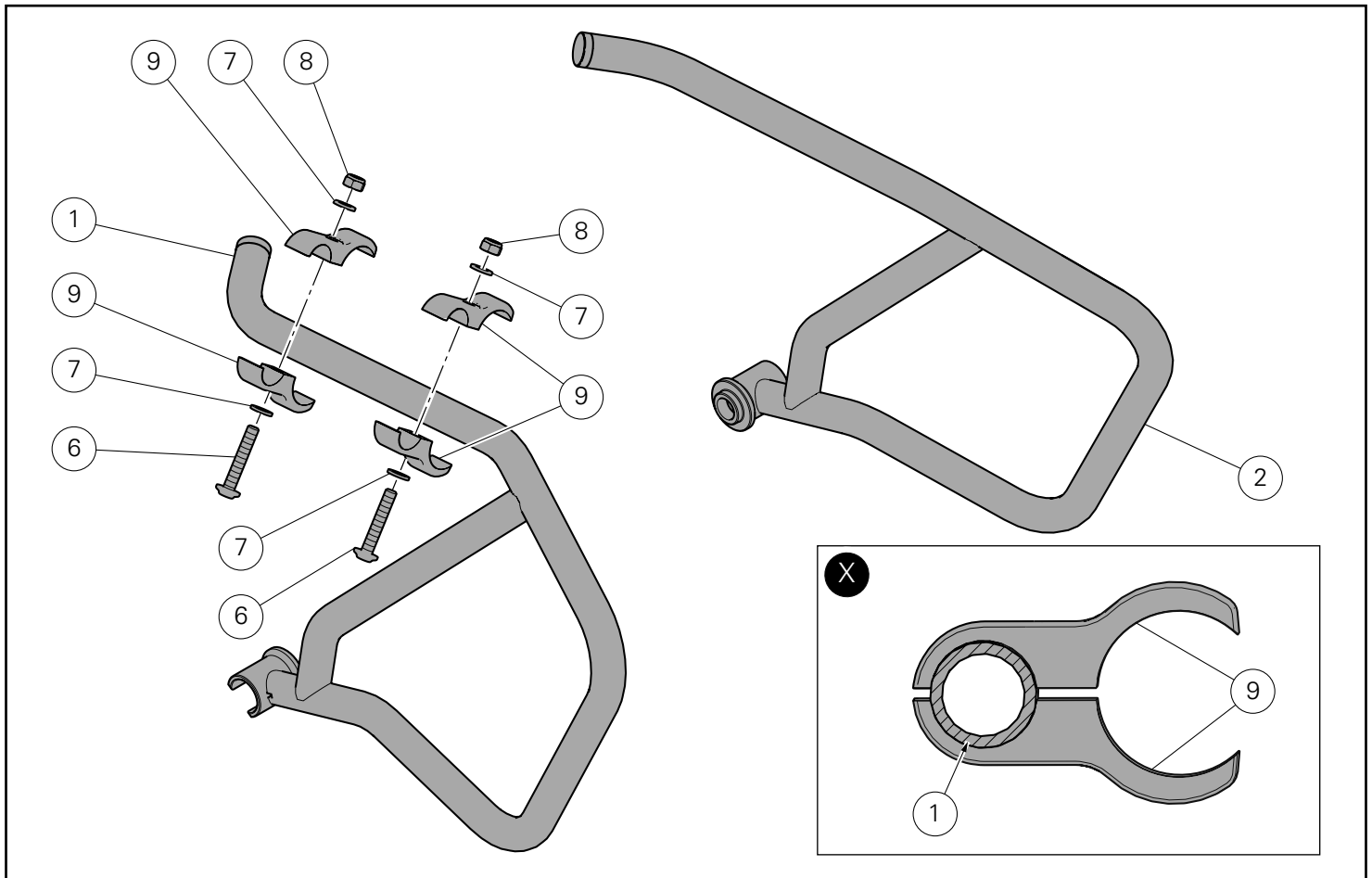

**Pré-montagem dos semiterminais no protetor do motor**

Introduza a anilha (7) no parafuso (6).

Posicione os 2 semiterminais (9) no protetor do motor direito(1) conforme mostrado na figura (X) e encoste o parafuso (6) por baixo.

Do lado superior, na saliência do parafuso (6), introduza a anilha (7) e atarraxe ligeiramente a porca autoblocante (8).

Repita a mesma operação para a montagem do segundo terminal no protetor do motor direito (1) e para os 4 semiterminais no protetor do motor esquerdo (2).

**Pre-assembly of half clamps on engine protection**

Fit washer (7) on screw (6).

Position no. 2 half clamps (9) on the RH engine protection (1) as shown in the figure (X) and start screw (6) from the bottom.

From the upper side, on the screw (6) projection, fit washer (7) and slightly screw the self-locking nut (8).

Repeat the same operation to fit the second clamp on the RH engine protection (1) and for the 4 half clamps on the LH engine protection (2).

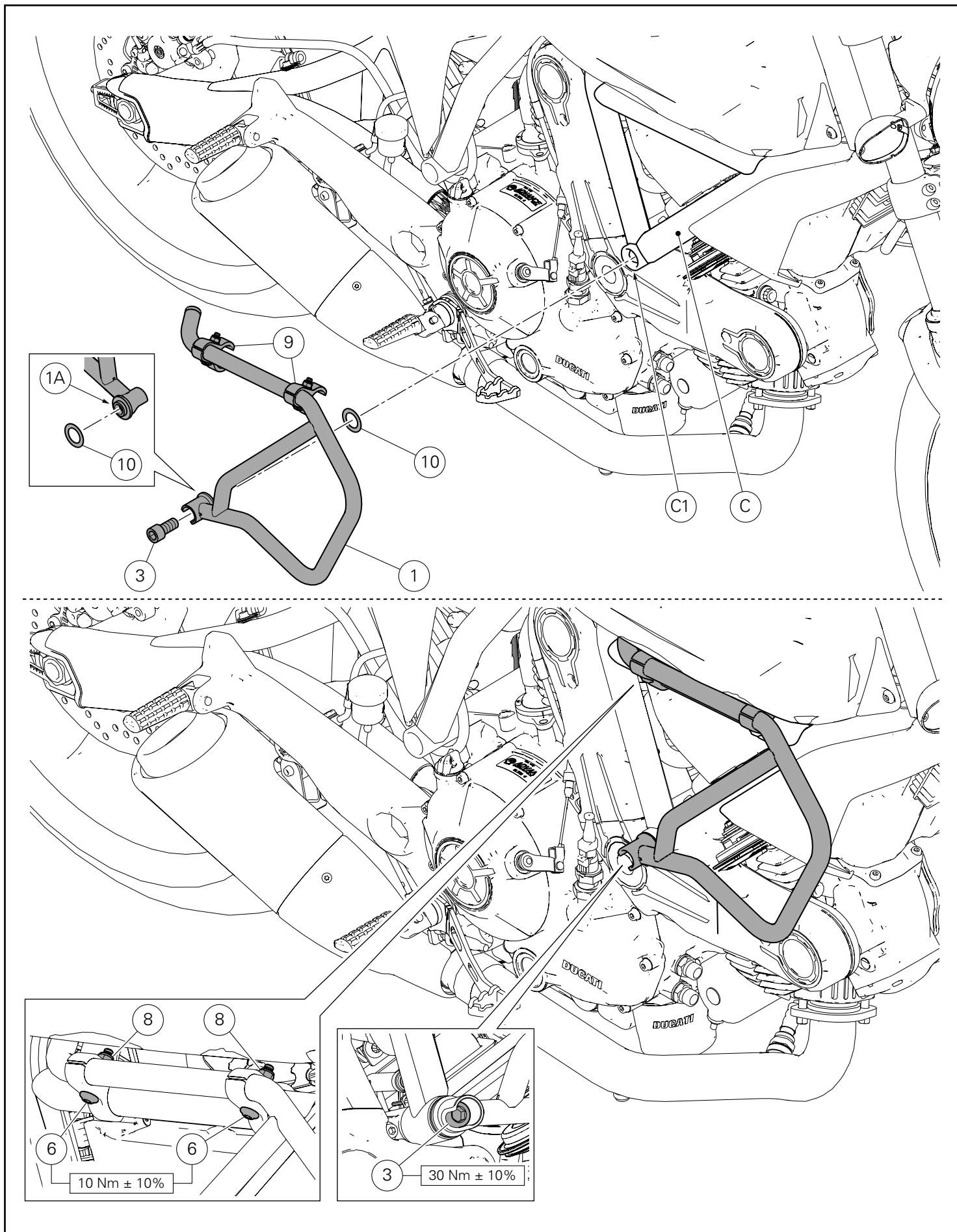

### Montagem do protetor do motor

Atuando do lado direito do veículo, engate os semiterminais (9) no chassi (C).

Introduza o apêndice (1A) na sede (C1), interpondo o espaçador (10).

Encoste o parafuso (3) no protetor do motor direito (1).

Aperte os 2 parafusos (6) ao binário indicado, mantendo as 2 porcas (8) bem firmes no lado oposto.

Aperte o parafuso (3) ao binário indicado.

Repita a mesma operação para a montagem do protetor do motor esquerdo.

### Fitting the engine protection

Working on the motorcycle RH side, fit the half clamps (9) onto frame (C).

Insert protrusion (1A) into seat (C1) with spacer (10) in between. Start screw (3) on RH engine protection (1).

Tighten no. 2 screws (6) to the specified torque while holding no. 2 nuts (8) from the opposite side.

Tighten screw 3 to the specified torque.

Repeat the same procedure to assemble LH engine protection.





## Kit paragolpes de tubos パイプエンジンガードキット



### Símbolos

Para una lectura rápida y racional se han empleado símbolos que evidencian situaciones de máxima atención, consejos prácticos o simples informaciones. Prestar mucha atención al significado de los símbolos porque su función consiste en omitir la repetición de conceptos técnicos o advertencias de seguridad. Los símbolos deben considerarse como verdaderos "apuntes". Consultar esta página cada vez que se tengan dudas sobre su significado.



#### Atención

El incumplimiento de las instrucciones indicadas puede crear una situación de peligro y ocasionar graves lesiones e incluso la muerte.



#### Importante

Indica la posibilidad de provocar un daño al vehículo y/o a sus componentes si no se siguen las instrucciones indicadas.



#### Notas

Suministra útiles informaciones sobre la operación en curso.

### Referencias

Las partes resaltadas en gris y la referencia numérica (Por ej. ①) representan el accesorio que se debe instalar y los eventuales componentes de montaje suministrados en el kit.

Las partes con referencia alfabética (Por ej. Ⓐ) representan los componentes originales presentes en la motocicleta.

Todas las indicaciones derecha o izquierda se refieren al sentido de marcha de la motocicleta.

### Advertencias generales



#### Atención

Las operaciones descritas en las siguientes páginas deben realizarse correctamente para no perjudicar la seguridad del piloto.



#### Atención

Las operaciones descritas en las siguientes páginas deben realizarse correctamente para no perjudicar la seguridad del piloto.



#### Notas

La documentación necesaria para realizar el montaje del Kit es el: MANUAL DE TALLER, relativo al modelo de moto en vuestro poder.



#### Notas

Si fuera necesario sustituir un componente del kit, consultar la tabla de recambios adjunta.

### シンボル

素早くかつ合理的に読み進めることができるように、本マニュアルではいくつかのシンボルを導入し、最大限の注意を払う必要がある状況や、推奨事項、または一般情報を明確にしています。技術的概念や安全に関する警告を繰り返し記載する必要がないように機能しているため、各シンボルの意味に十分注意してください。シンボルは、実際上の“覚え書き”であると考えてください。シンボルなどの意味がわからなくなったり疑問に思う場合は、必ずこのページで調べるようにしてください。



#### 注記

この説明書に従わずに使用すると危険な状況を招き、重大なけが、あるいは死をももたらす原因となることがあります。



#### 重要

この説明書に従わずに使用すると、車体及び/ 又はその部品に損害を招く可能性があります



#### 参考

操作中の内容に関する有用な情報を掲載しています。

### 参照

灰色で表示する部品、および参照番号 (Es. ①) で表示する部品は、キットに付属する取り付け部品および組み立て部品を示します。

参照アルファベット (Es. Ⓐ) で表示する部品は、車両に付属するオリジナル部品を示します。

すべての右及び左の指示は車体の進行方向を向いたものです。

### 一般警告事項



#### 警告

以下のページに記載されている作業が規定通りに実施されないと、ライダーの安全性を脅かすおそれがあります。



#### 警告

以下のページに記載されている作業が規定通りに実施されないと、ライダーの安全性を脅かすおそれがあります。



#### 参考

キットの取り付けに必要な資料：お手持ちの車両モデルに対応するワークショップマニュアル。



#### 参考

キットの部品を交換する必要がある場合は、添付のスペアパーツ表を参照してください。

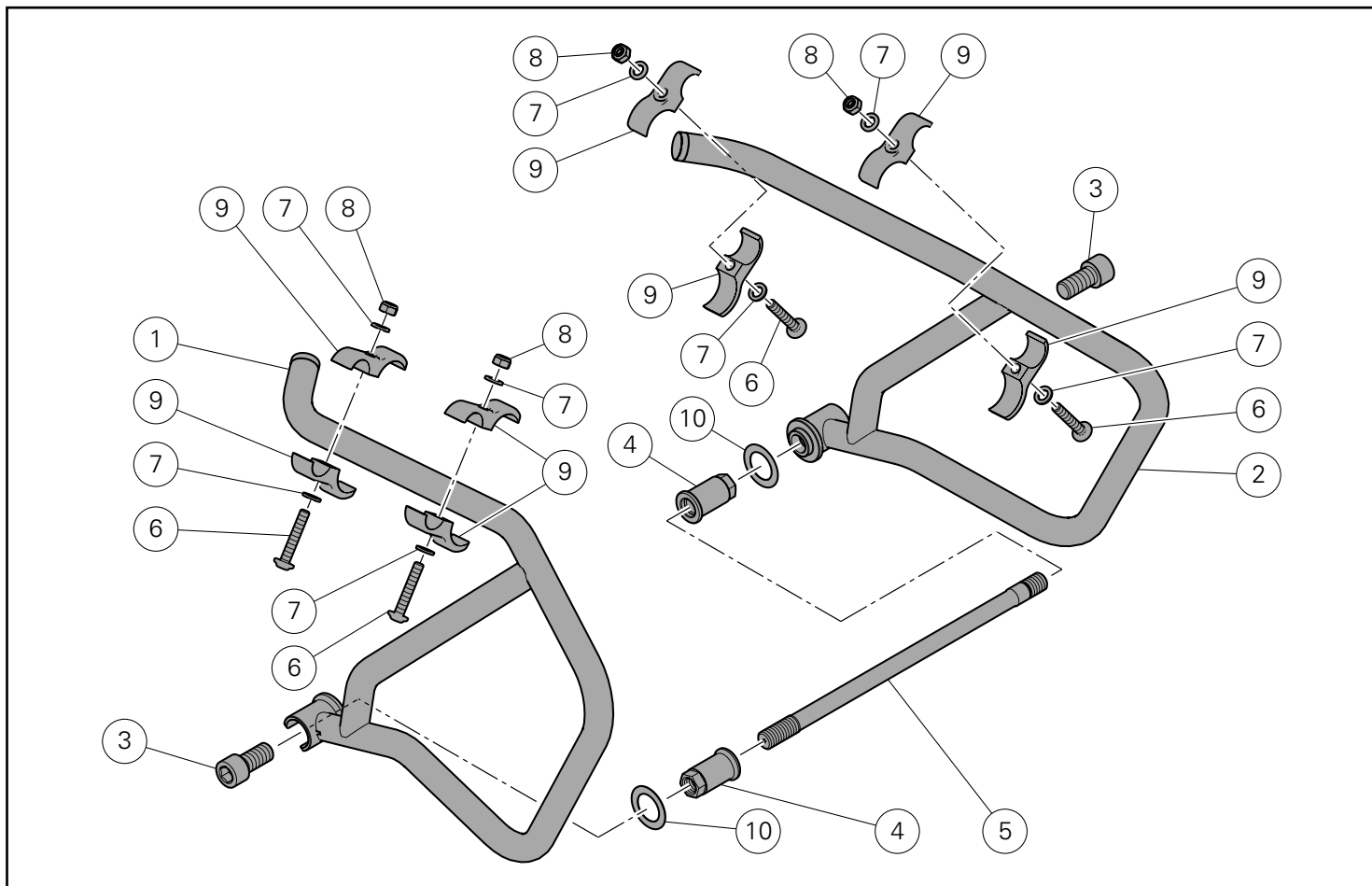

Pos.	Denominacion	説明
1	Protector motor derecho	右エンジンガード
2	Protector motor izquierdo	左エンジンガード
3	Tornillo especial TCEI	スクリュー TCEI
4	Tuerca especial	専用ナット
5	Tornillo especial	専用スクリュー
6	Tornillo	スクリュー
7	Arandela	ワッシャー
8	Tuerca autobloqueante	セルフロックナット
9	Semiborne	ハーフクランプ
10	Separador	スペーサー

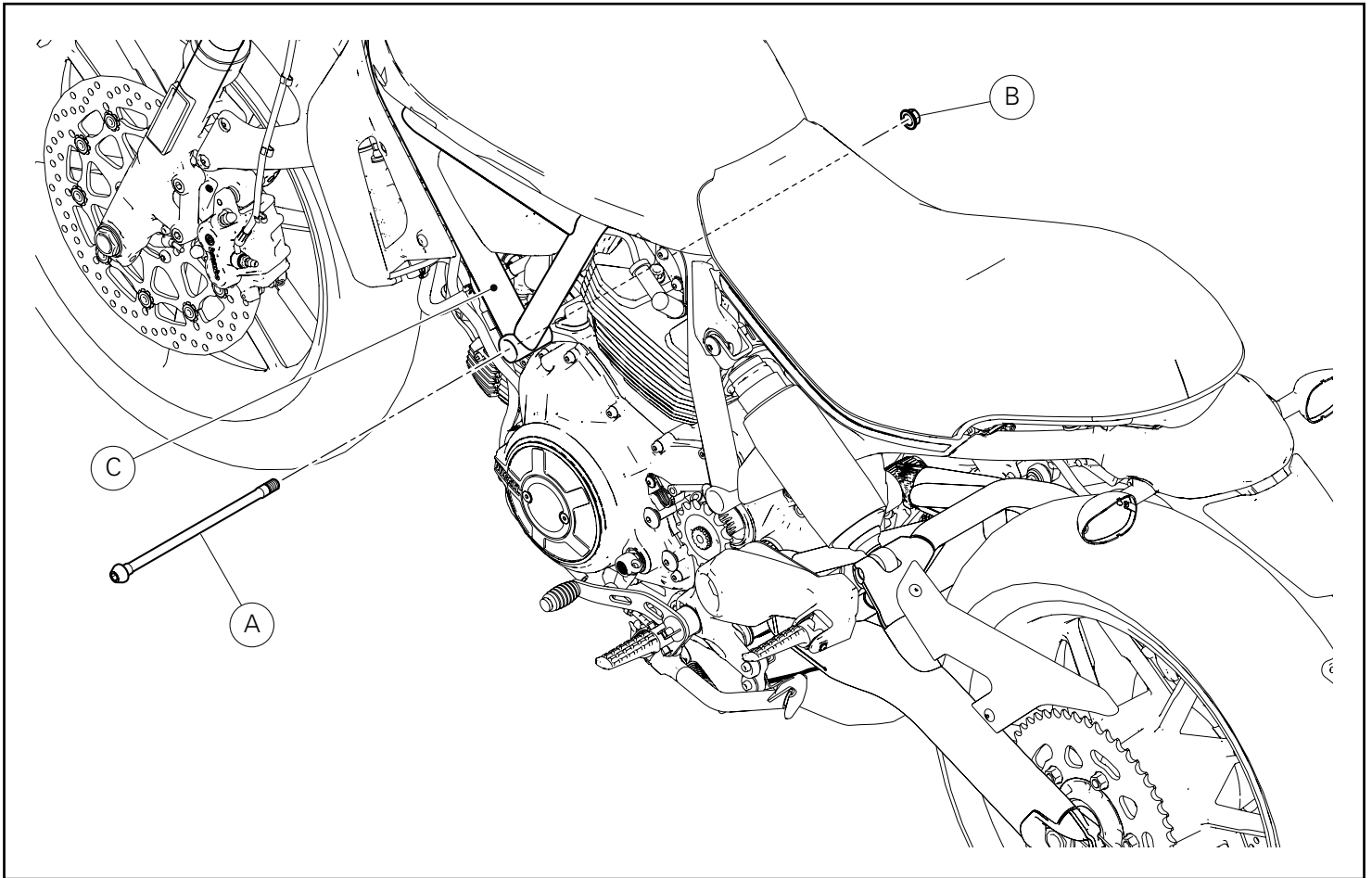

## Desmontaje componentes originales

## オリジナル部品の取り外し

### Desmontaje tornillo especial bastidor

### フレーム専用スクリューの取り外し



#### Importante

Durante el procedimiento de desmontaje del tornillo especial bastidor soportar de forma adecuada el bloque motor



#### 重要

フレーム専用スクリューの取り外し作業中は、エンジンプロックを適切に支えます。

Desatornillar el tornillo especial (A) del bastidor (C) manteniendo, del lado opuesto, la tuerca (B).  
Quitar la tuerca (B).

反対側からナット (B) を保持しながら、専用スクリュー (A) をフレーム (C) から緩めて外します。  
ナット (B) を取り外します。

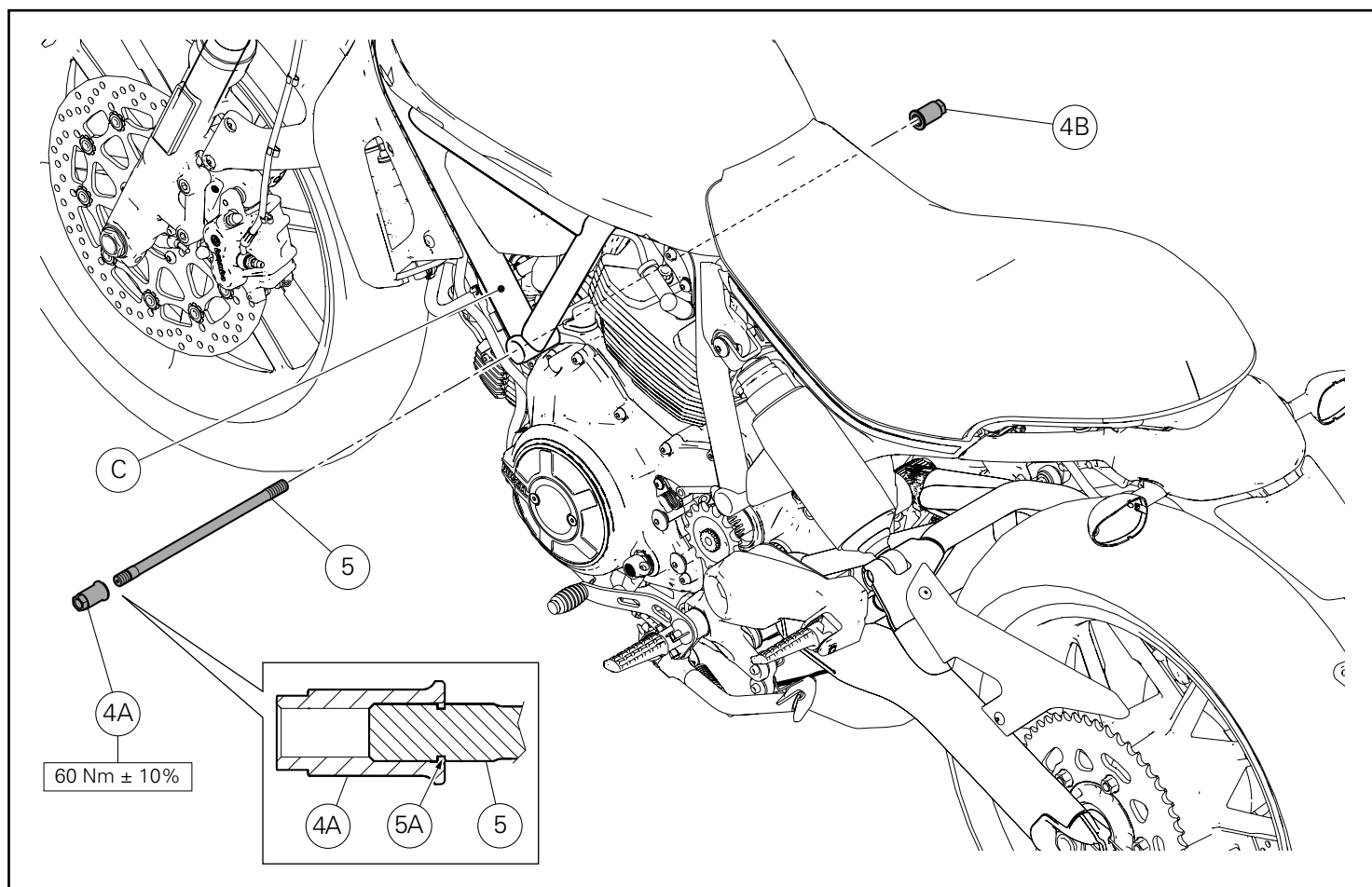

## Montaje componentes kit

### ● Importante

Controlar, antes del montaje, que todos los componentes se encuentren limpios y en perfecto estado.  
Adoptar todas las precauciones necesarias para evitar daños en la superficie exterior de los componentes donde se debe operar.

### Montaje tornillo especial

Aplicar LOCTITE 601 en la rosca de las 2 tuercas especiales (4A) y (4B).

Montar la tuerca especial (4A) en el tornillo especial (5), atornillándola hasta la ranura (5A) presente en el tornillo mismo, como se indica en el recuadro.

Aplicar GRASA blanca en toda la barra del tornillo especial (5), prestando atención a no aplicar grasa en la rosca.

Introducir el tornillo especial (5) en el bastidor (C), atornillando la tuerca especial (4A) hasta el tope.

Introducir la segunda tuerca especial (4B) del lado opuesto.

Ajustar la primera tuerca (4A) al par de apriete indicado manteniendo, del lado opuesto, la segunda tuerca (4B).

## キット部品の取り付け

### ● 重要

取り付け前にすべての部品に汚れがなく、完璧な状態であることを確認します。作業する部品の外側表面を傷つけないために、必要な予防措置を取ってください

### 専用スクリューの取り付け

2 個の専用ナット (4A) および (4B) のネジ山に LOCTITE 601 を塗布します。

枠内に示されているように、専用ナット (4A) を専用スクリュー (5) に取り付け、スクリューにある溝 (5A) まで締めます。

ホワイトグリースを、専用スクリュー (5) のネジ部に付着しないように注意して、レッグ全体に塗布します。

専用スクリュー (5) を、専用ナット (4A) が奥まで当たるように、フレーム (C) に差し込みます。

2 個目の専用ナット (4B) を反対側から差し込みます。

反対側から 2 個目のナット (4B) を保持しながら、最初のナット (4A) を規定のトルクで締め付けます。

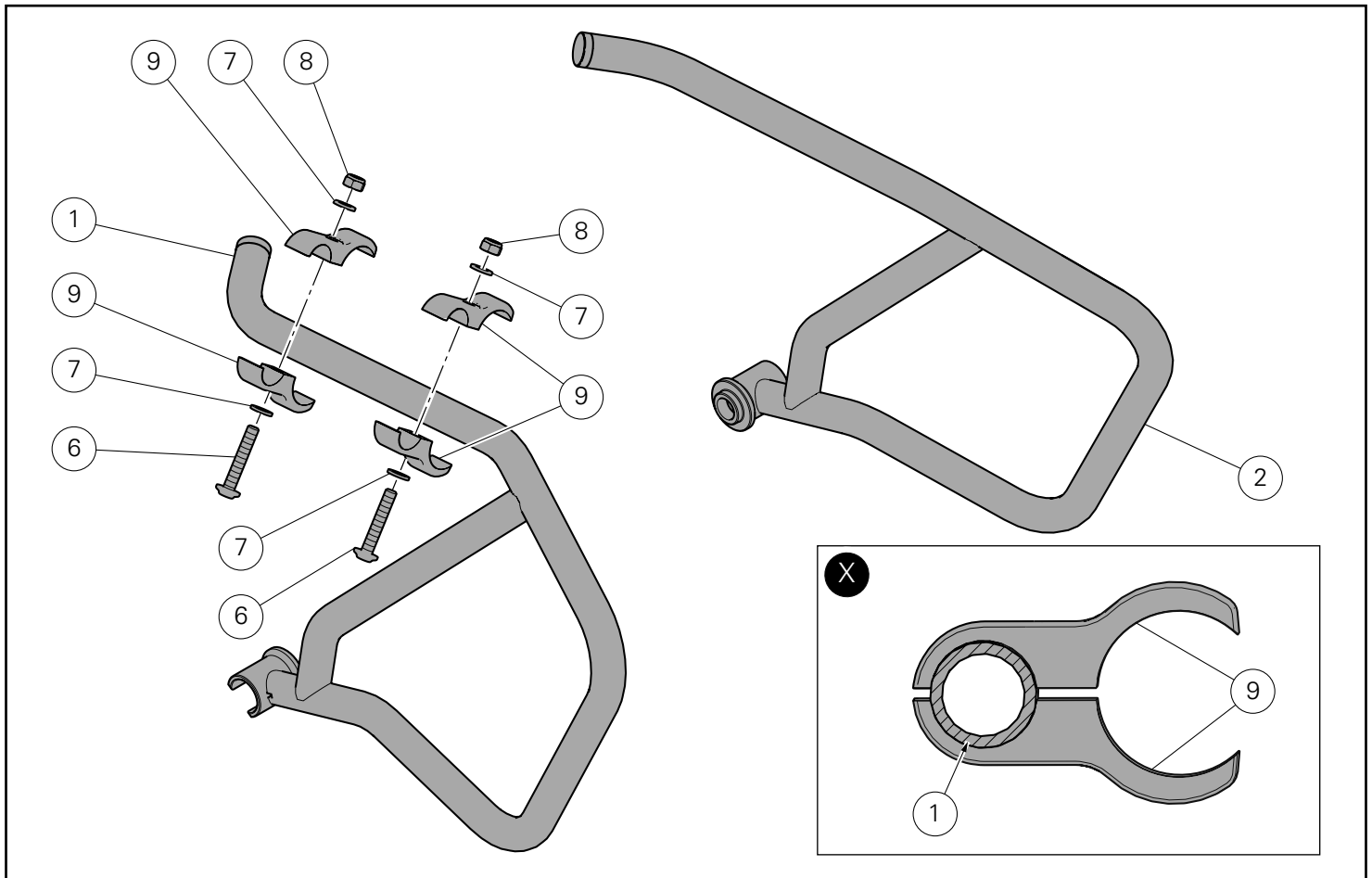

### Premontaje semibornes en el protector motor

Introducir la arandela (7) en el tornillo (6).  
Colocar los 2 semibornes (9) en el protector motor derecho (1) como ilustra la figura (X) e introducir el tornillo (6) desde abajo.  
Del lado superior, en la parte sobresaliente del tornillo (6) introducir la arandela (7) y atornillar ligeramente la tuerca autobloqueante (8).  
Repetir la misma operación para el montaje del segundo borne en el protector motor derecho (1) y para los 4 semibornes en el protector motor izquierdo (2).

### ハーフクランプのエンジンガードへの仮取り付け

ワッシャー (7) をスクリュー (6) に挿入します。  
図 (X) のように 2 つのハーフクランプ (9) を右側のエンジンガード (1) に配置し、下側からスクリュー (6) を差し込みます。  
上側からスクリュー (6) の突起部にワッシャー (7) を挿入し、セルフロックナット (8) を軽く締めます。  
2 番目のクランプの右側のエンジンガード (1) への取り付け、および 4 つのハーフクランプの左側のエンジンガードへ (2) の取り付けにも同様の操作を繰り返します。

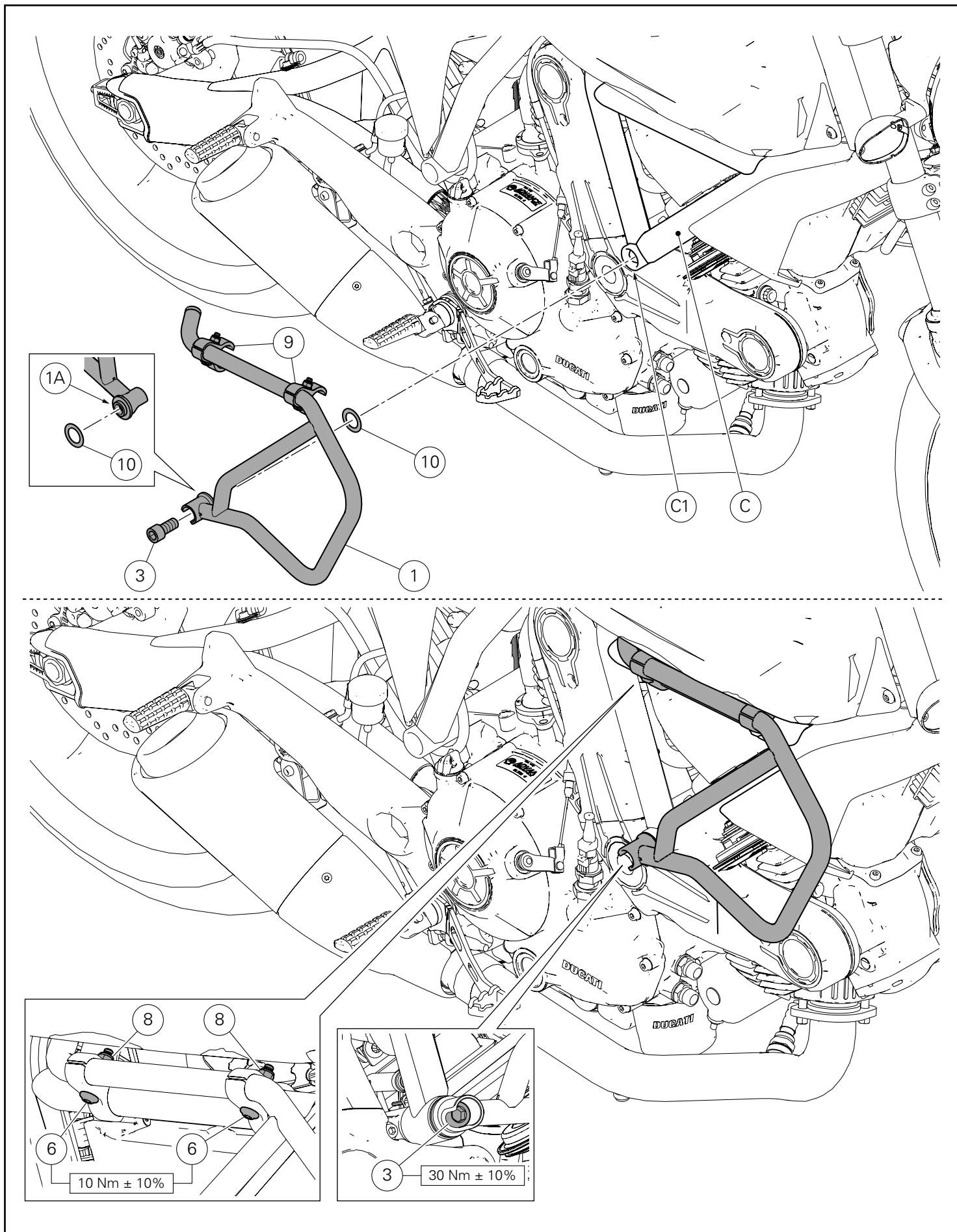

## Montaje protector motor

Operando del lado derecho de la motocicleta, enganchar los dos semibornes (9) en el bastidor (C).

Introducir la extremidad (1A) en el alojamiento (C1) interponiendo el separador (10).

Introducir el tornillo (3) en el protector motor derecho (1).

Ajustar los 2 tornillos (6) al par de apriete indicado manteniendo, del lado opuesto, las 2 tuercas (8).

Ajustar el tornillo 3 al par de apriete recomendado.

Repetir esta misma operación para montar el protector motor izquierdo.

## エンジンガードの取り付け

車両の右側で作業します。ハーフクランプ (9) をフレーム (C) にかけます。

間にスペーサー (10) を差し込み、付属部品 (1A) を所定の位置 (C1) に挿入します。

スクリュー (3) を右側のエンジンガード (1) に差し込みます。

反対側から 2 個のナット (8) を保持しながら、2 本のスクリュー (6) を規定のトルクで締め付けます。

スクリュー (3) を規定のトルクで締め付けます。

左側エンジンガードの取り付けについても同様の操作を繰り返します。







**DUCATI** PERFORMANCE accessories

## レース専用部品 ご注文書

### ご注文商品

1 P/N

商品名

2 P/N

商品名

3 P/N

商品名

4 P/N

商品名

5 P/N

商品名

### お客様ご記入欄

私は上記レース専用部品を下記車両に装着し、サーキット走行のみに利用し、一般公道には利用しません。

車台番号 ZDM

モデル名

お客様署名

ご注文日

### ドゥカティ正規ネットワーク店記入欄

お客様に上記レース専用部品を販売し、レース専用部品のご利用方法を説明いたしました。

販売店署名

販売日

年

月

日

販売店様へお願い

- 上記ご記入の上、弊社アフターセールス部までFAXしてください。FAX:03-6692-1317
- 取り付け車両1台に1枚でご使用ください。